



Tow-Trust Towbars

IMPORTANT

Please read General Notes (overleaf) before fitting.

TYPE: TR 804 RENAULT LAGUNA '94 -

ITEM	QTY	DESCRIPTION	ITEM	QTY	DESCRIPTION
A	1	Crossbar	F	4	M16 x 50 Bolts, Nuts & Washers
B	2	Handed Side Arms	G	4	M12 x 30 Bolts, 2 Nuts & 4 Washers
C	1	Extension Bar	H	2	M10 Nuts & Washers only
D	1	48mm Tube	I	4	M8 x 35 Bolts, S/P & Flat Washers
E	4	M8 Caged Nuts	J	2	10 x 50 Washers
			K	2	Bolt Caps

- 1) Remove the rear exhaust hanger and the two rear screws securing the heat shield.
- 2) Locate the four existing holes in the rear panel and insert the four caged nuts (Item E).
- 3) Locate the existing holes in each chassis member and loosely bolt Items B with Item D inside the chassis and Item J on the outer face.
- 4) Using Item I, loosely bolt Item B to the caged nuts (Item E) in the rear panel.
- 5) Using Item G, loosely bolt Item A to Item B.
- 6) Fully tighten all nuts and bolts, starting with Item I (the M8 x 35's). Ensure the towbar is rigid and secure.
- 7) Replace the heat shield and exhaust hanger.
- 8) Using Item F, bolt Item C to Item A.
- 9) Using Item F, bolt the ball bracket and wiring plate (not supplied in this kit) to the mounting plate.

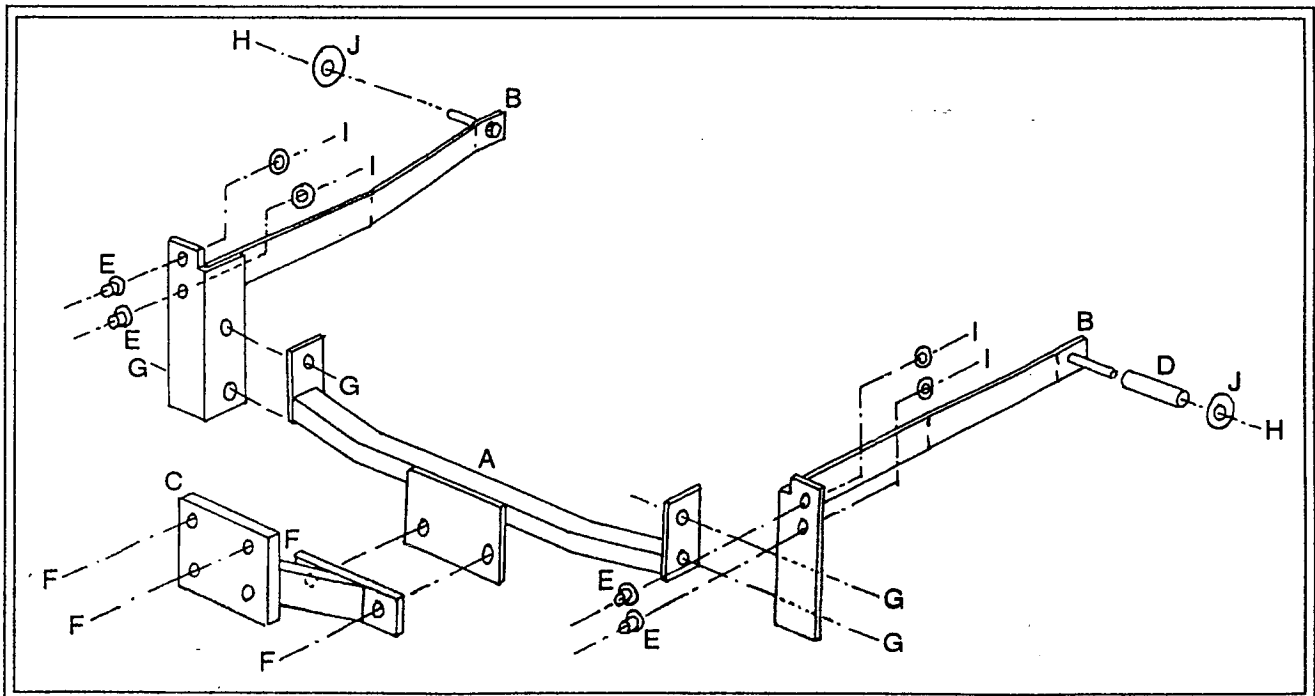

TOW WITH TRUST